

A2FE (Fixed Plugin) Bent Axis Motors 2022

Fixed Plugin, High Pressure Hydraulic Bent Axis Piston Motors, High Pressure, 450/500 BAR Working Pressure. High Rotational Speed, High Efficiency, Slim Design, Cast Iron Motor Body, Re-Designed in 2022.

Designation;

28cc, 32cc, 41cc, 50cc, 56cc,
63cc, 80cc, 90cc, 108cc, 125cc

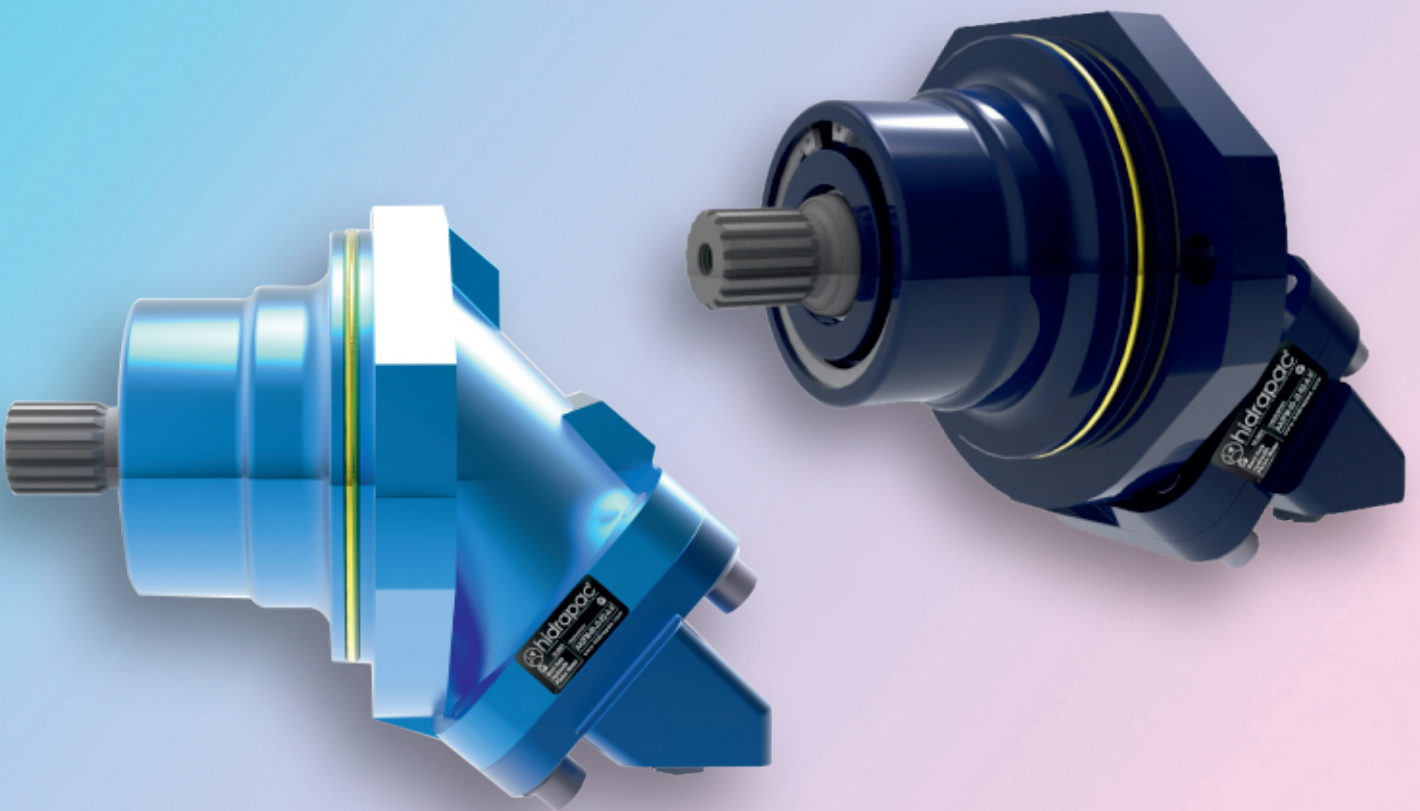

Hidrapac **Store**

www.HIDRAPAC.com.tr

Characteristics of the A2FE (Fixed Plugin) Flange Bent Axis Motors

MOTOR MODEL	DISPL. (cc)	CONTINUOUS MAX. SPEED (rpm)	INTERMITTENT MAX. SPEED (rpm)	MAX. FLOW ABSORBED (l/mn)	TORQUE BAR (m.N/bar)	TORQUE AT 350 BAR (m.N)	THEORETICAL MAX. POWER AT 400 BAR (HP / kW)	MAX. ALLOW PRESSURE CONTN./PEAK (bar)	WEIGHT (kg)
28 cc	28.0	6300	6900	158	0.40	139	140.0 / 104.4	400 / 450	11.4
32 cc	32.0	6300	6900	202	0.50	178	180.5 / 134.4	400 / 450	11.5
41 cc	41.0	5600	6200	230	0.65	228	205.2 / 153.1	400 / 450	11.6
50 cc	50,3	5000	5500	252	0.80	280	224.1 / 167.5	400 / 450	18.1
56 cc	56,0	5000	5500	280	0.90	320	244.5 / 187.1	400 / 450	18.1
63 cc	63.0	5000	5500	315	1.00	351	281.6 / 209.1	400 / 450	18.2
80 cc	80,4	4500	5000	362	1.27	447	323.6 / 241.5	400 / 450	26.1
90 cc	90,1	4500	5000	405	1.43	500	361.5 / 269.9	400 / 450	26.2
108 cc	108	4000	4400	435	1.70	598	328.8 / 245.6	400 / 450	33.2
125 cc	125	3400	4400	428	2.00	698	382.6 / 284.6	400 / 450	33.8

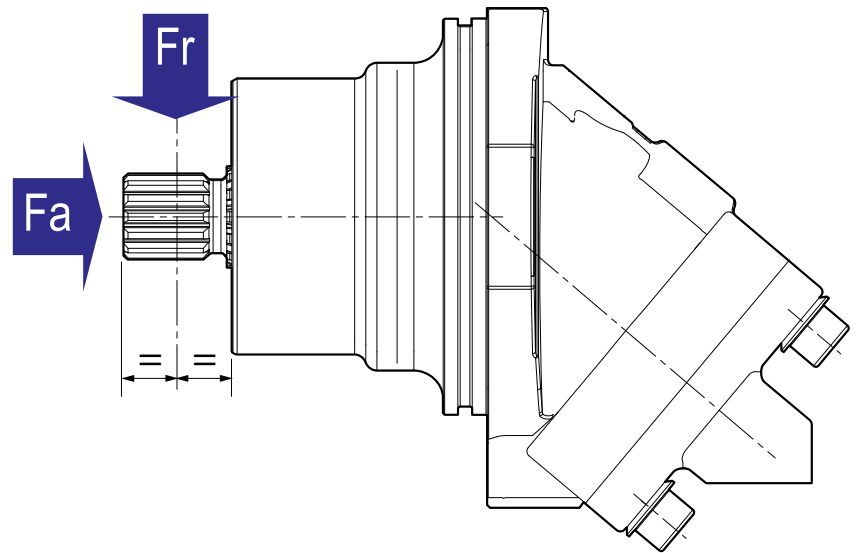

Motor model	28 cc	32 cc	41. 45	50 cc	56, 63cc	80,90,108	125 cc
Fr (lbf)	1350	1462.5	1462.5	1686	2023	2812	3262
Fr (N/bar)	6000	6500	6500	7500	9000	12500	14500
Fa (lbf)	0.42	0.46	0.62	0.62	0.77	1.24	1.33
Fa (N/bar)	(27)	(30)	(40)	(40)	(50)	(80)	(86)

Ordering Code; A2FE - Fixed Plugin Bent Axis Motors

Model Code	Displacement	Shaft Type	Flange + Cover Type	Rotation	Sealing
A2FE	28	S14	B2-R45	W	V
A2FE Bent Axis Hydraulic Motor Fixed Plugin	28	S14 Splined Shaft W30x2x30x14x9g	B2 2 Bolt ISO 3019-2	W Direction of Rotation Reversible Independet	V Viton High Pressure Seal
	32				
	41				
	50				
	56				
	63				
	80				
	90				
108	S16 Splined Shaft W35x2x30x16x9g	R45 SAE Flange Ports Bottom			
125					
	S18 Splined Shaft W40x2x30x18x9g				
	S21 Splined Shaft W45x2x30x21x9g				

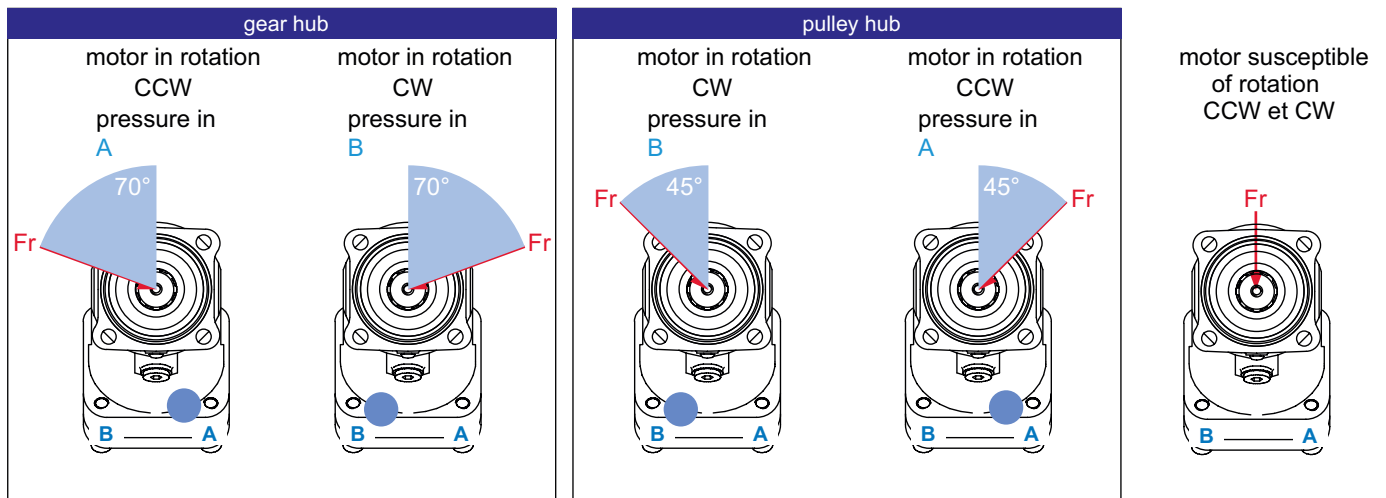

A2FE - 28 cc (Fixed Plugin) - 2 Bolt

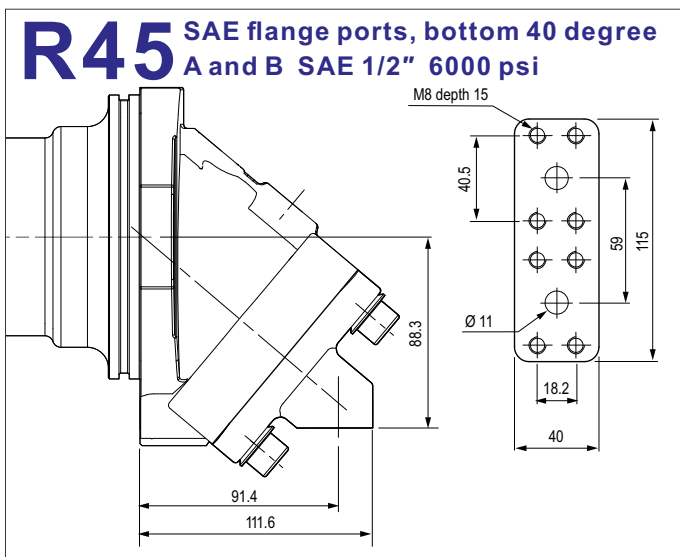
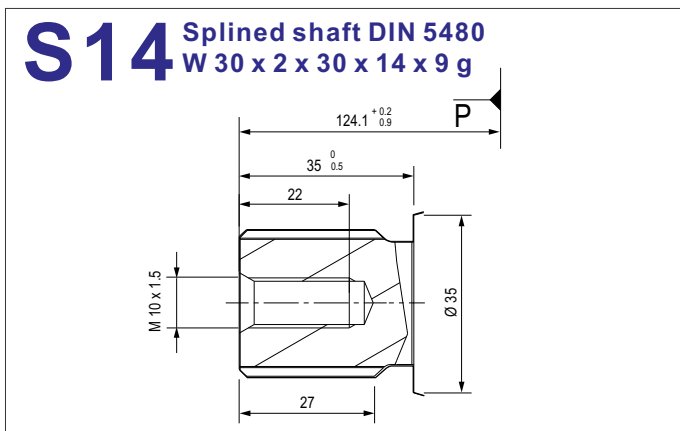
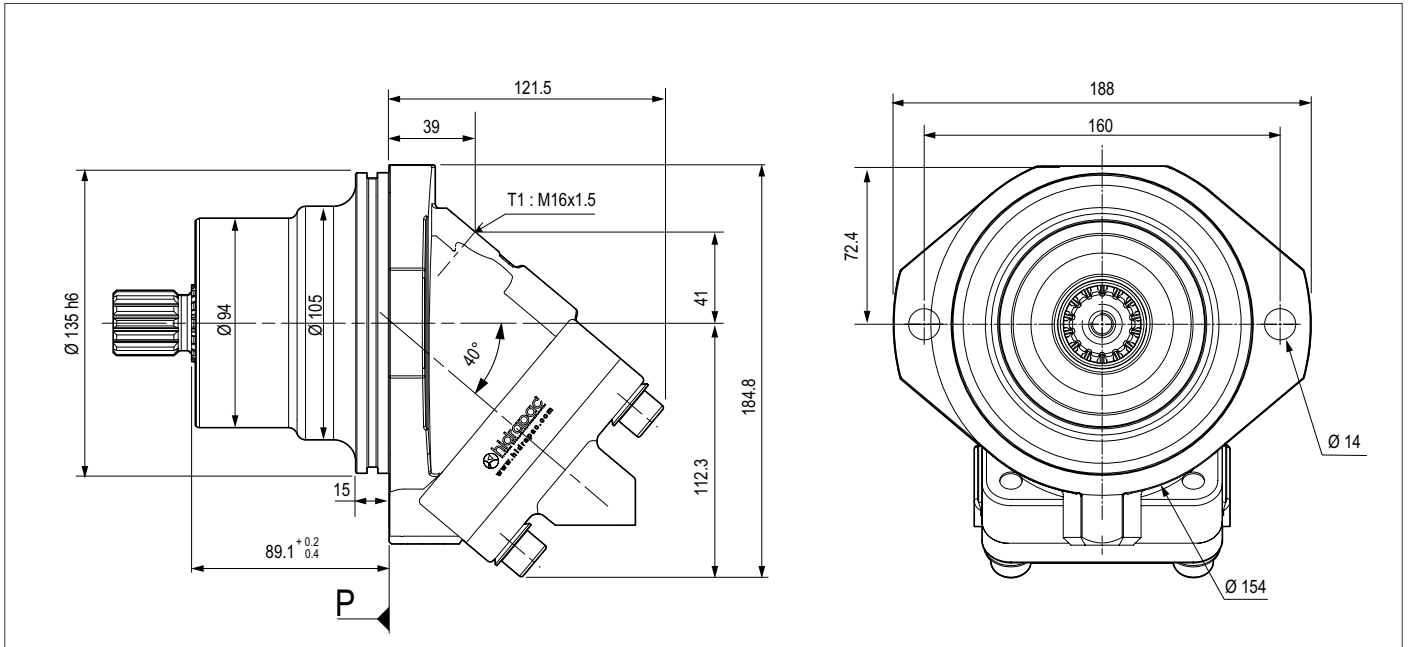

A2FE - 32 cc (Fixed Plugin) - 2 Bolt

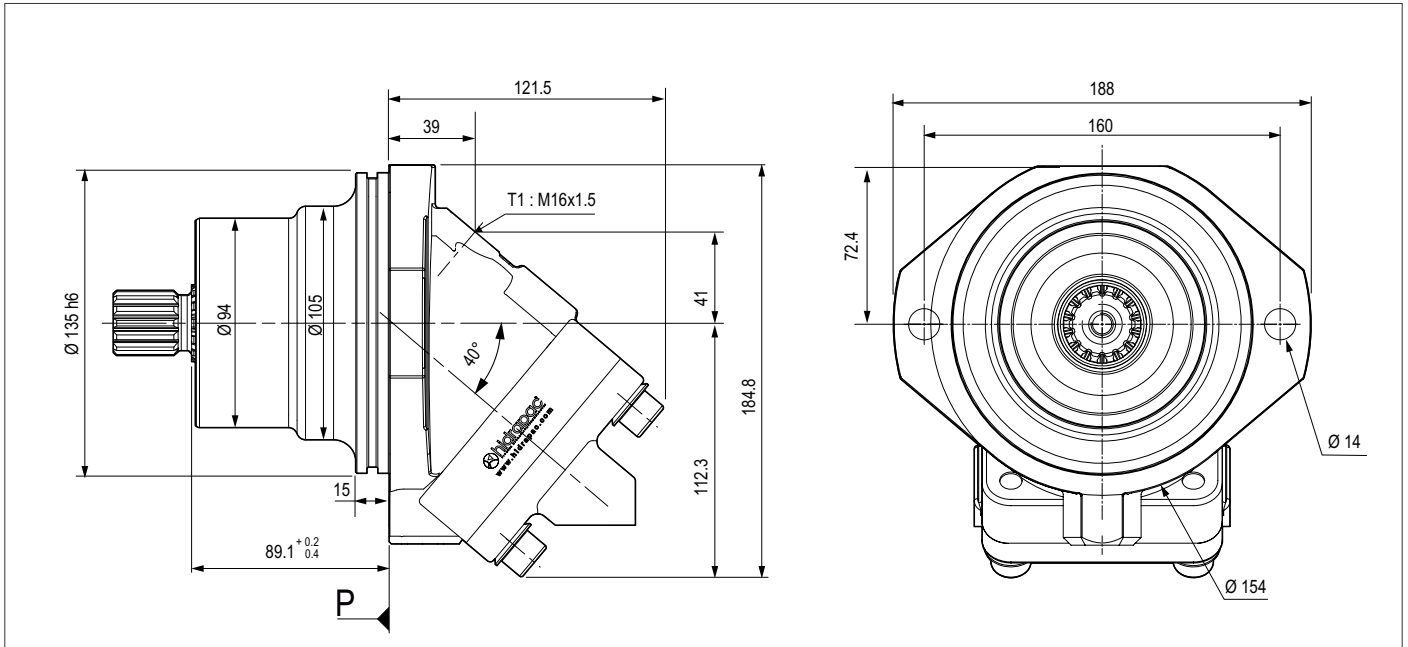

S14 Splined shaft DIN 5480 W 30 x 2 x 30 x 14 x 9 g

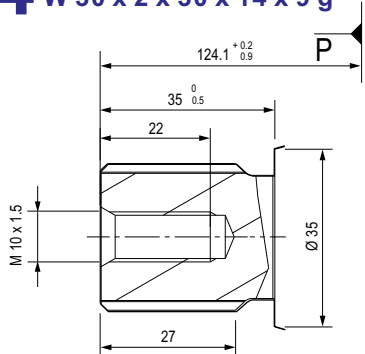

R45 SAE flange ports, bottom 40 degree A and B SAE 1/2" 6000 psi

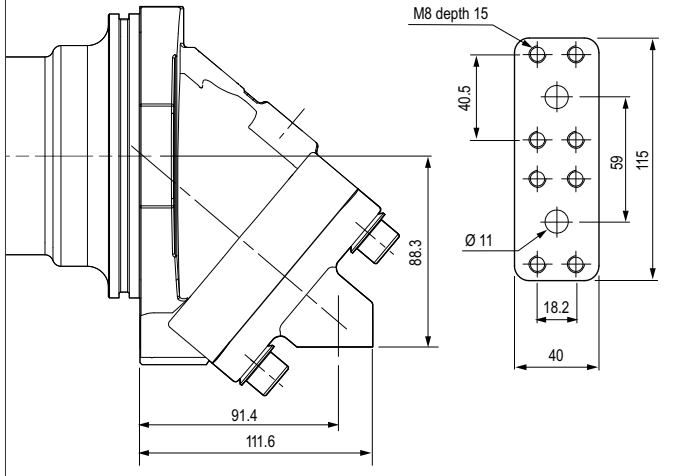

A2FE - 41 cc (Fixed Plugin) - 2 Bolt

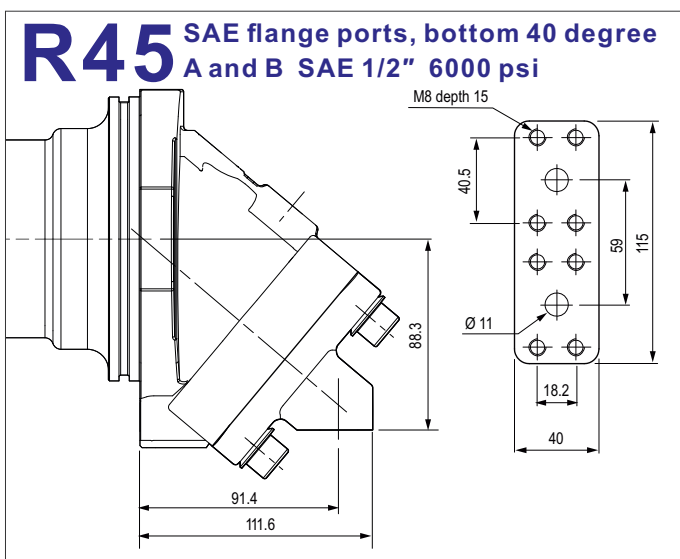
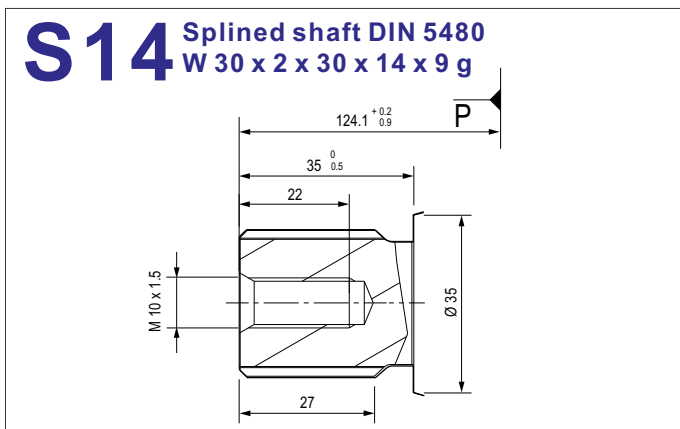
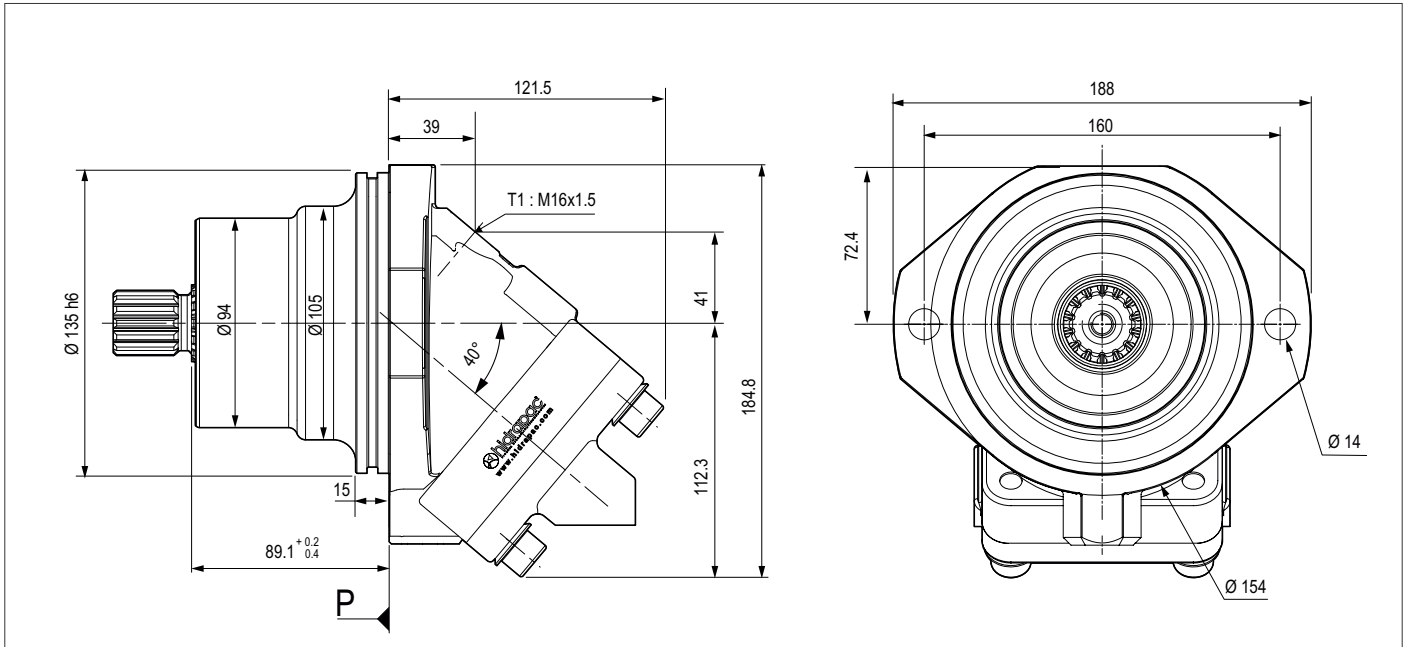

A2FE - 50 cc (Fixed Plugin) - 2 Bolt

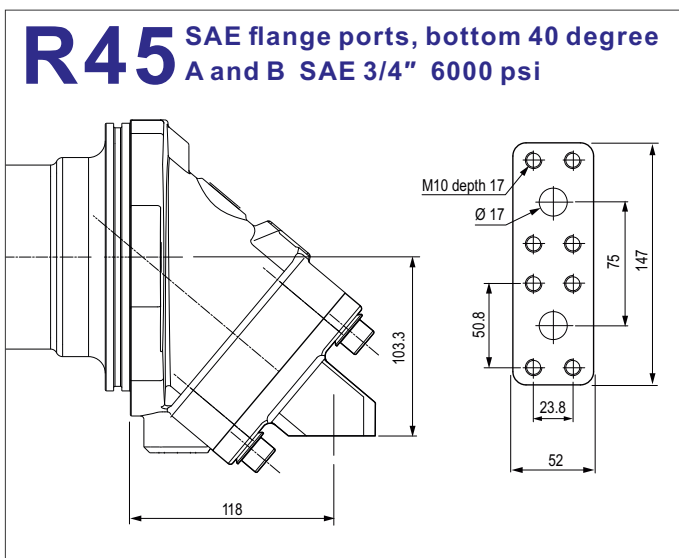
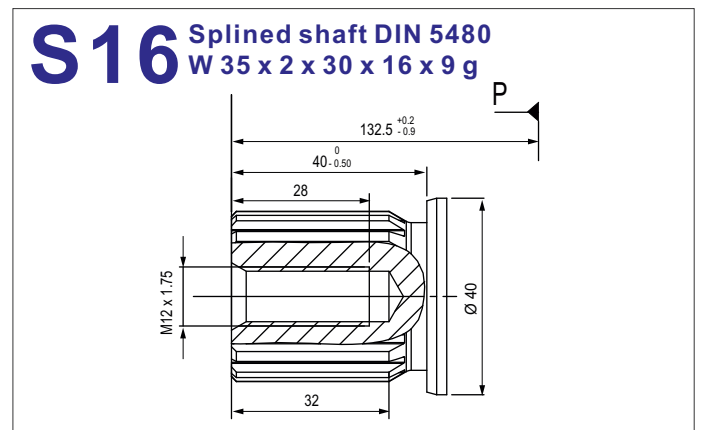
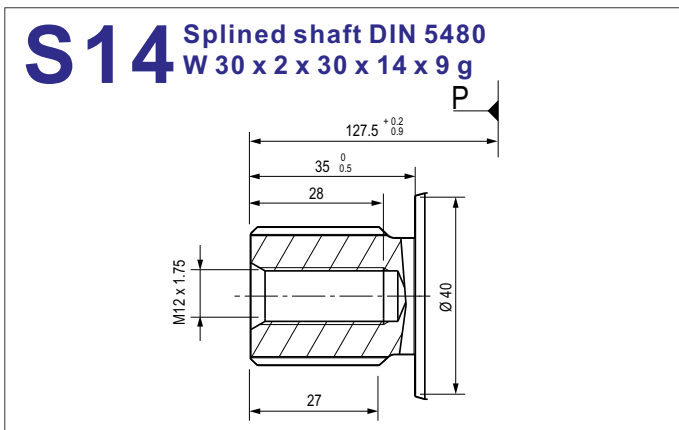
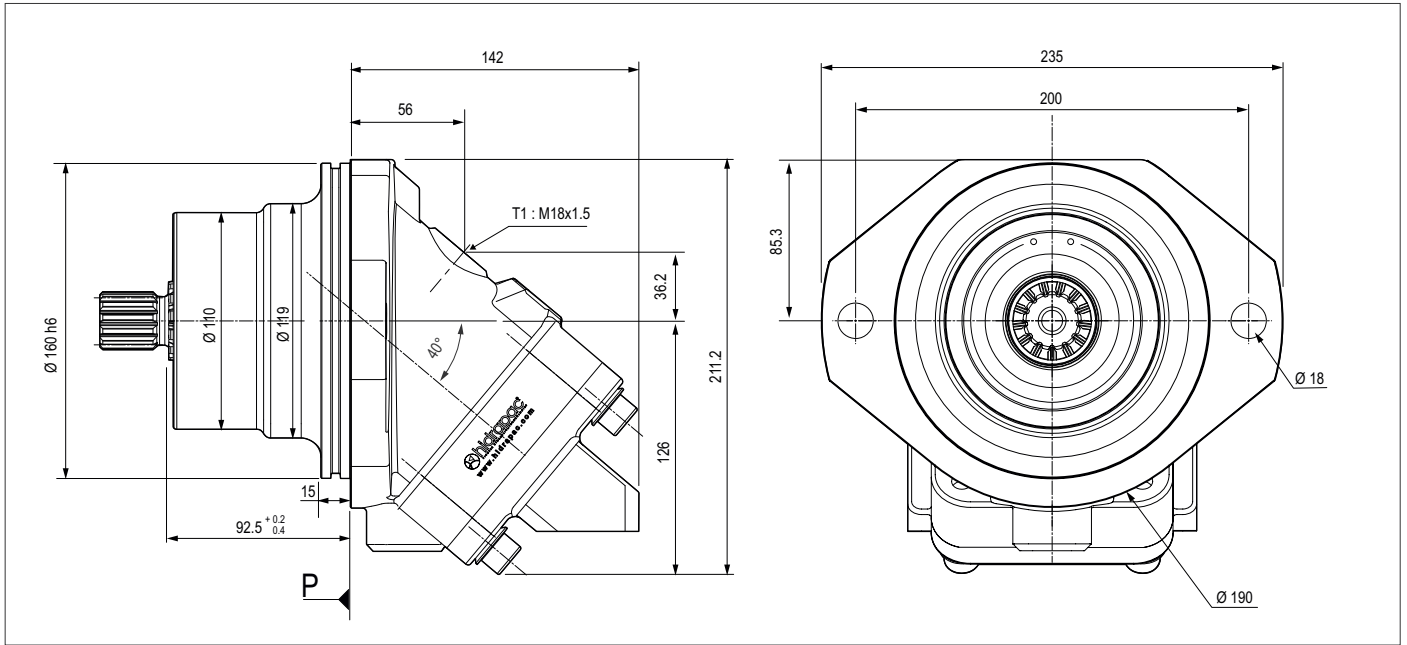

A2FE - 56 cc (Fixed Plugin) - 2 Bolt

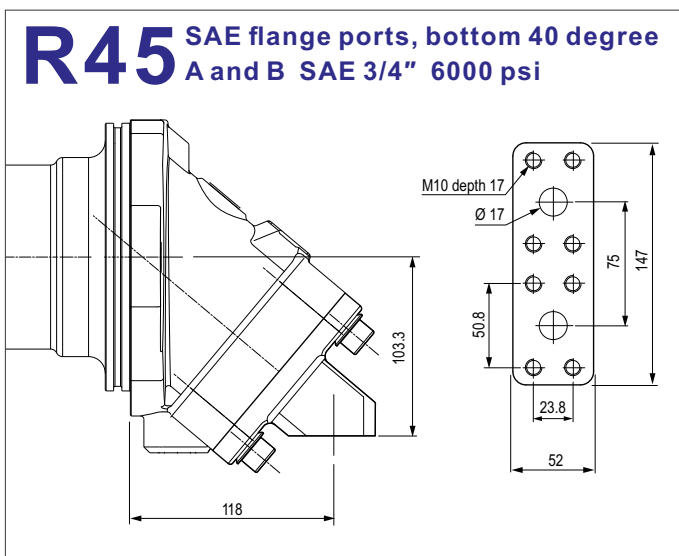
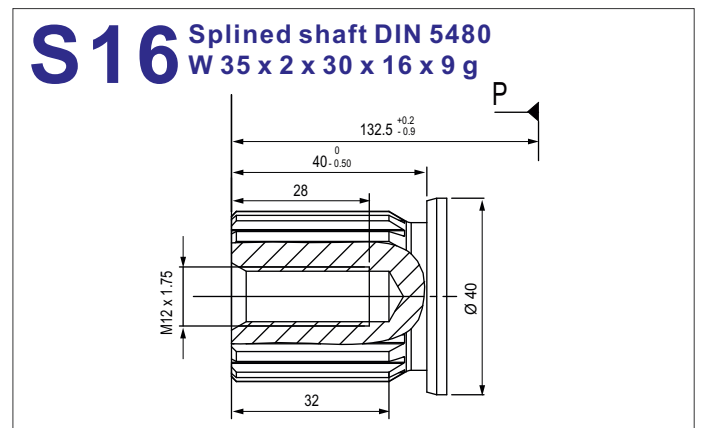
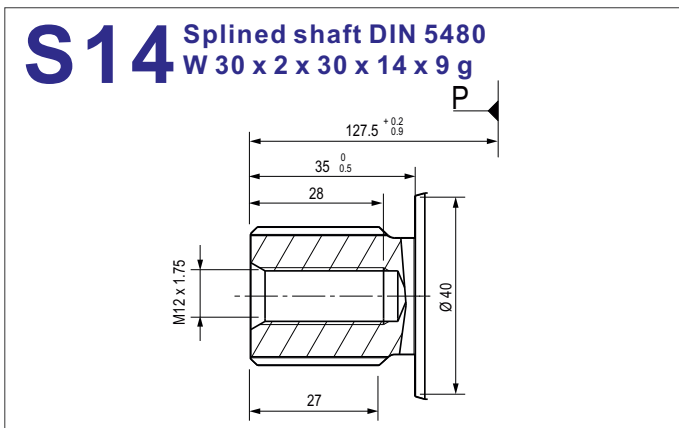
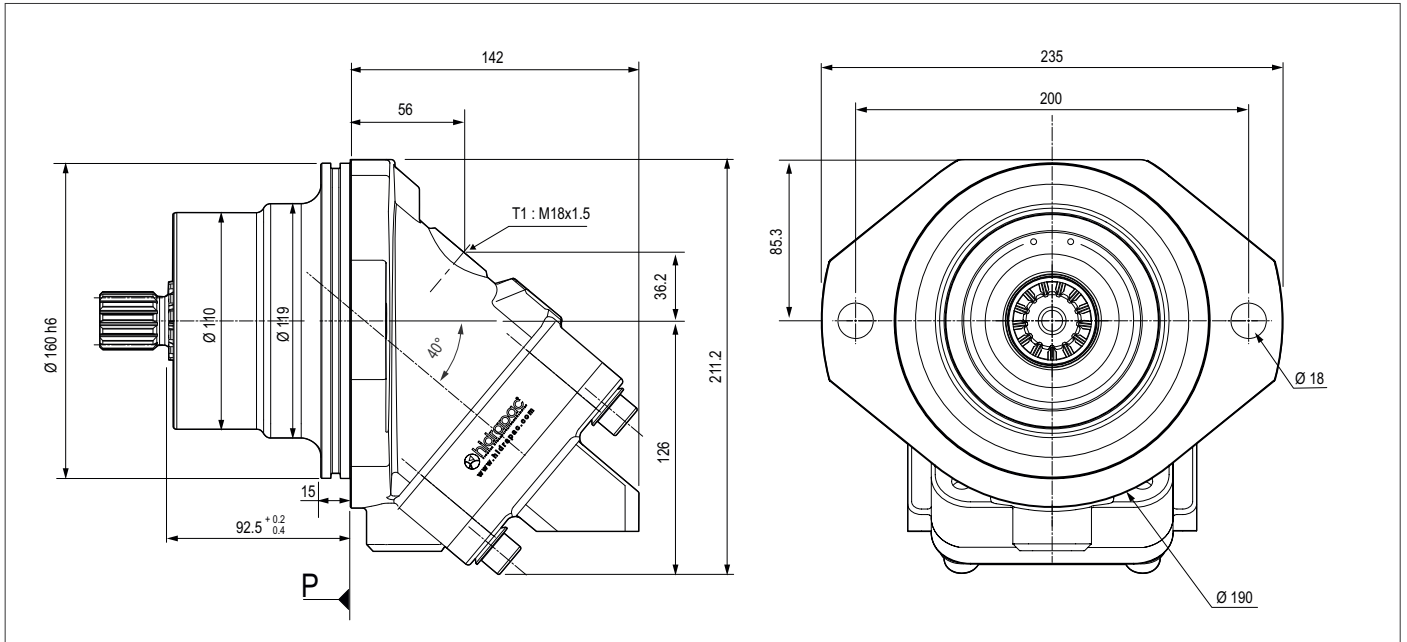

A2FE - 63 cc (Fixed Plugin) - 2 Bolt

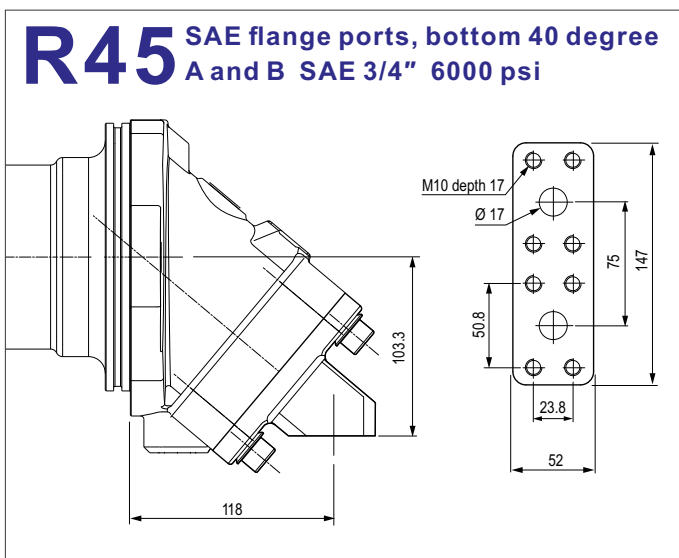
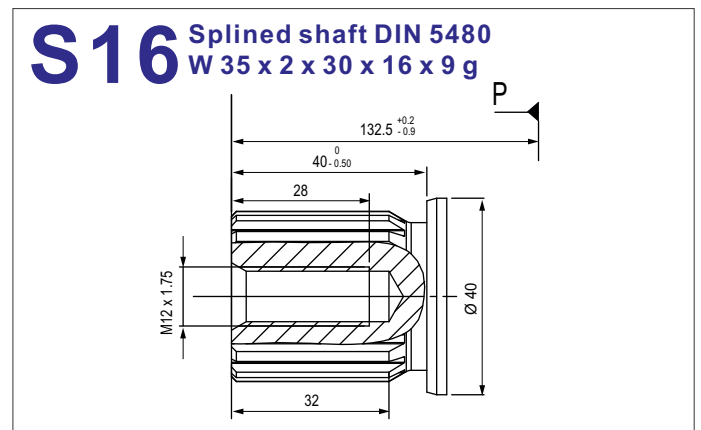
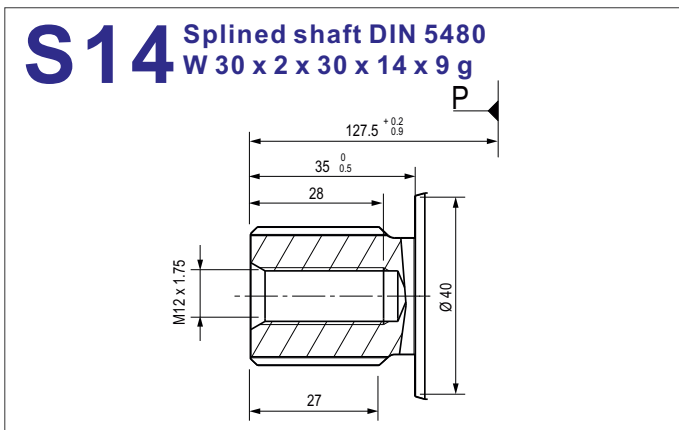
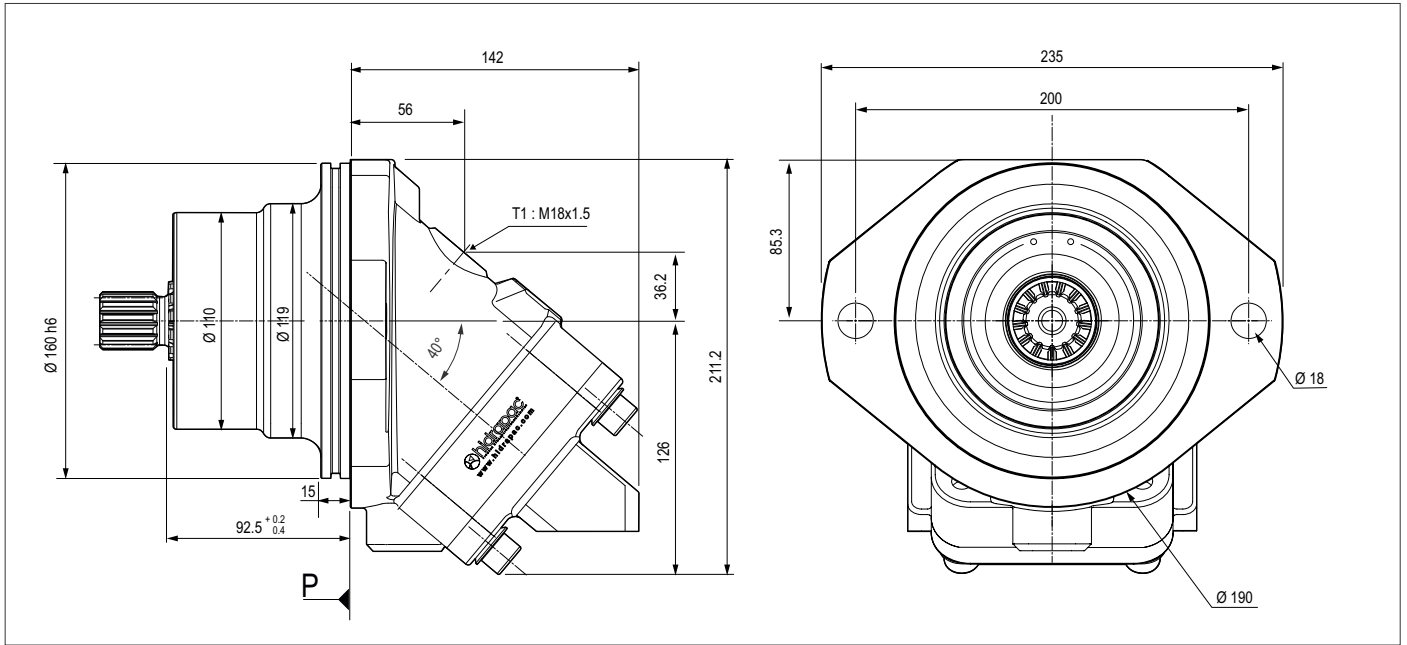

A2FE - 80 cc (Fixed Plugin) - 2 Bolt

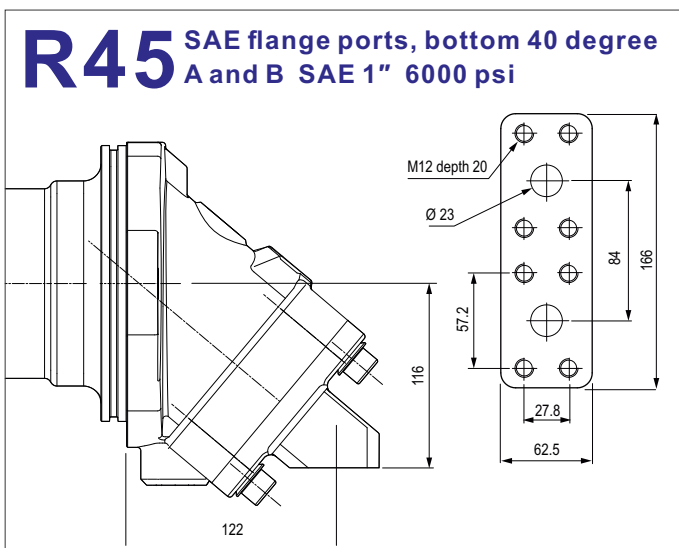
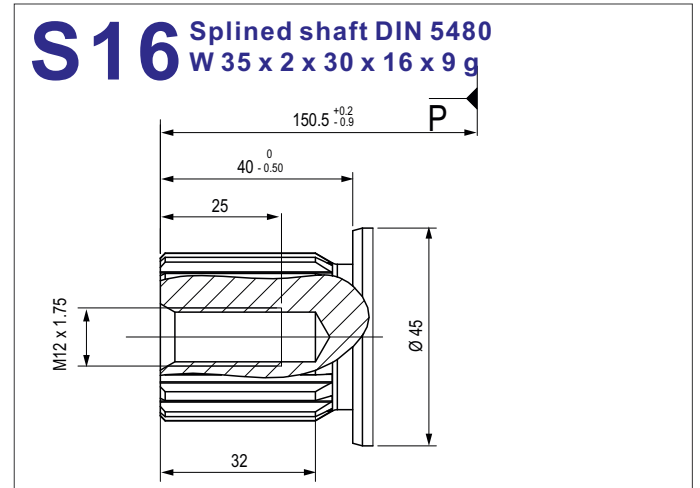
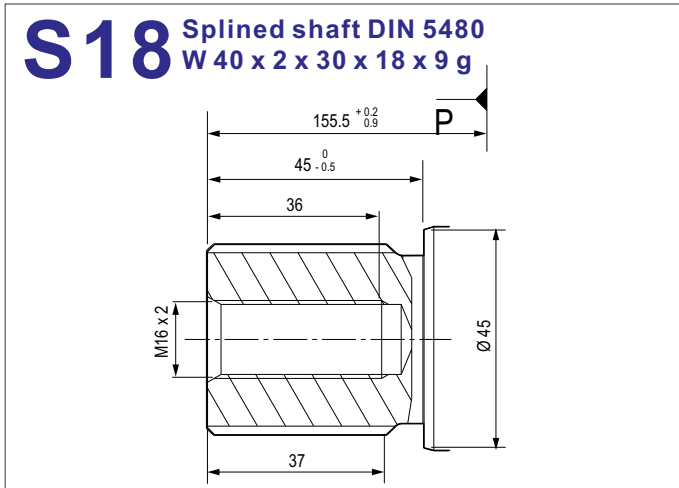
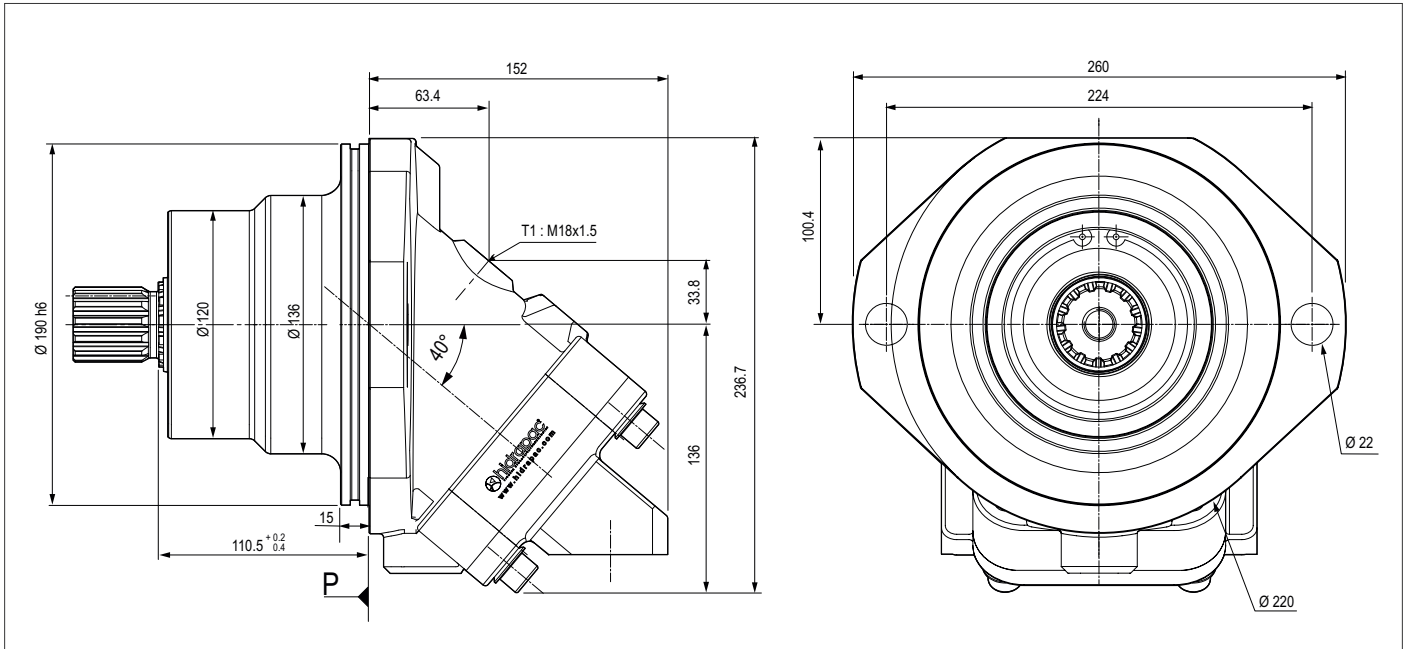

A2FE - 90 cc (Fixed Plugin) - 2 Bolt

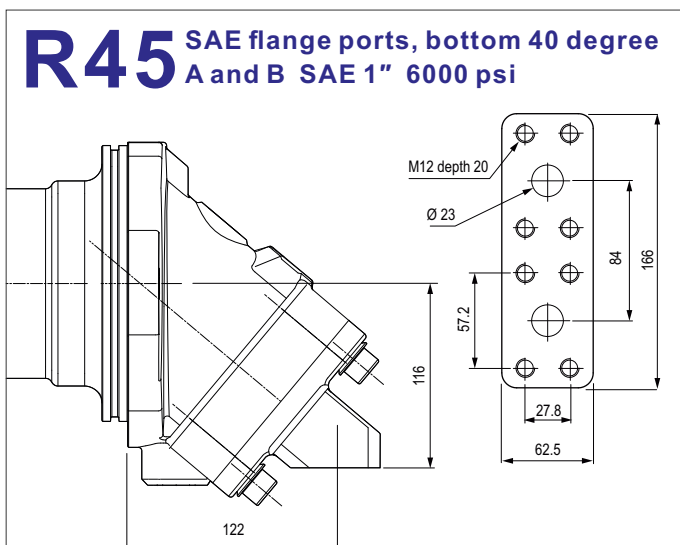
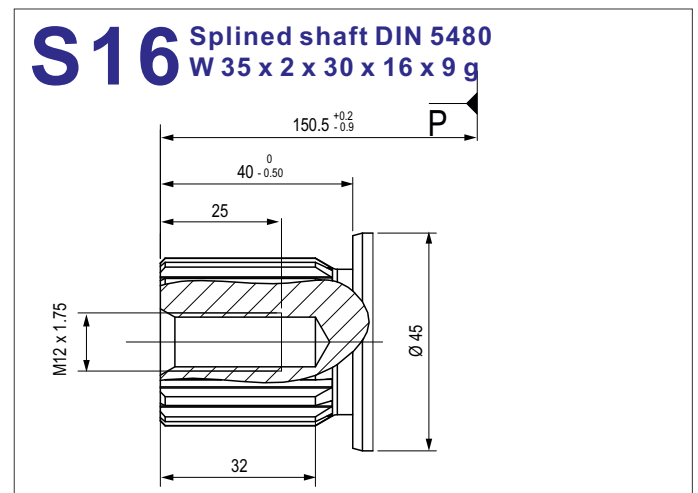
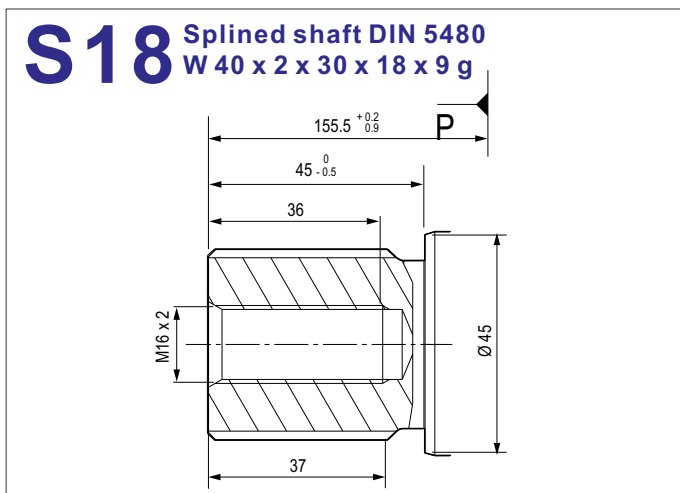
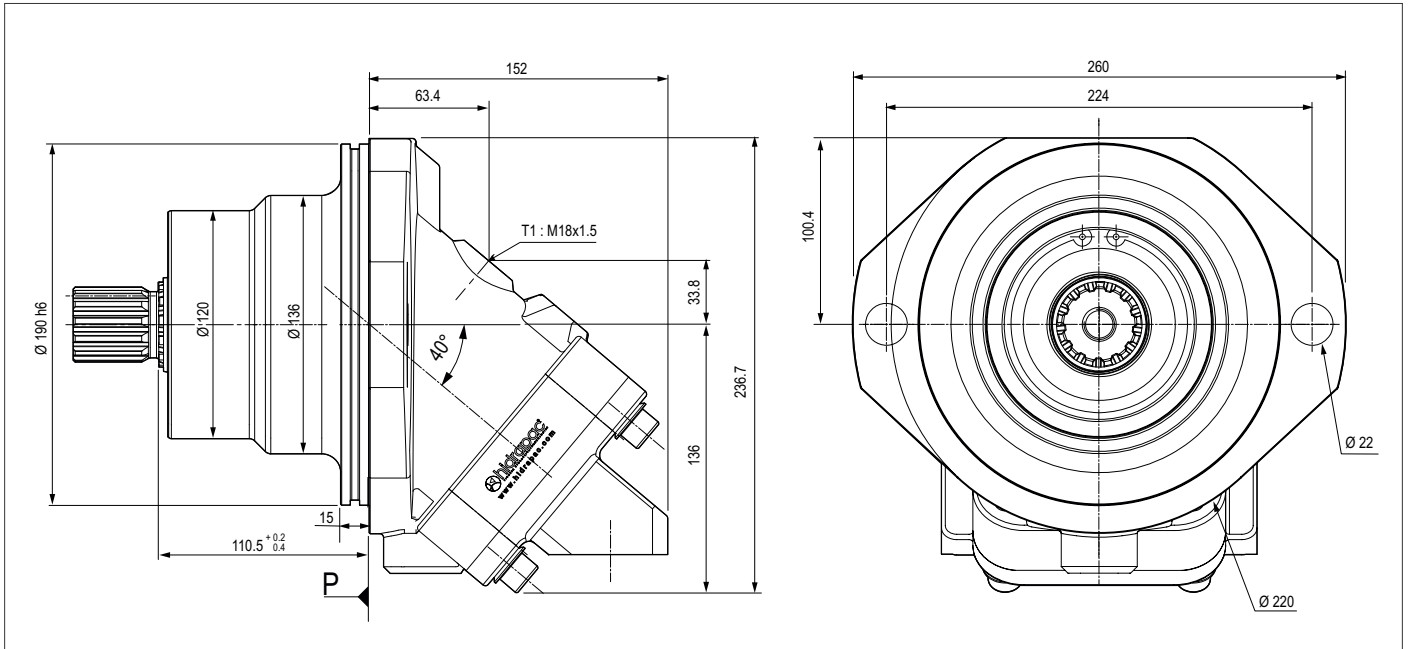

A2FE - 108 cc (Fixed Plugin) - 2 Bolt

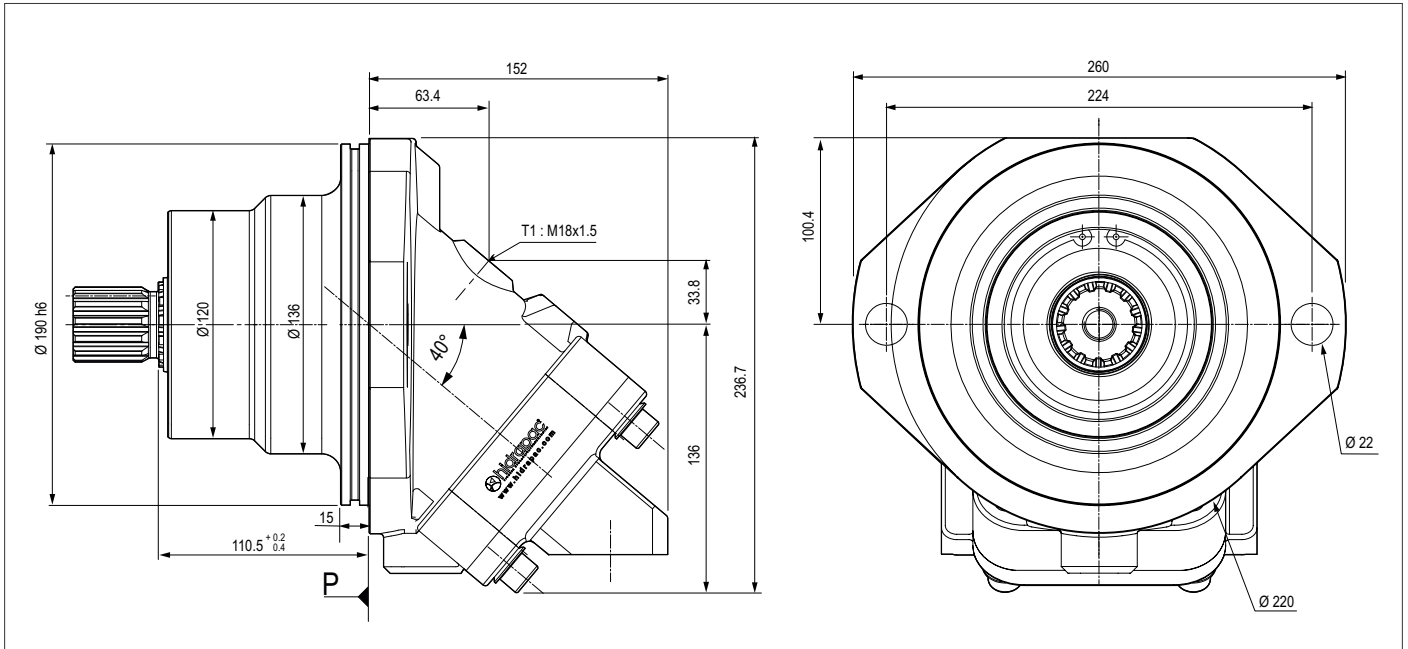

S18 Splined shaft DIN 5480 W 40 x 2 x 30 x 18 x 9 g

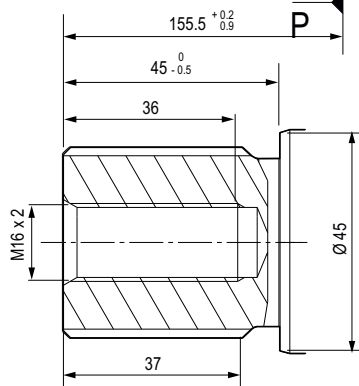

S16 Splined shaft DIN 5480 W 35 x 2 x 30 x 16 x 9 g

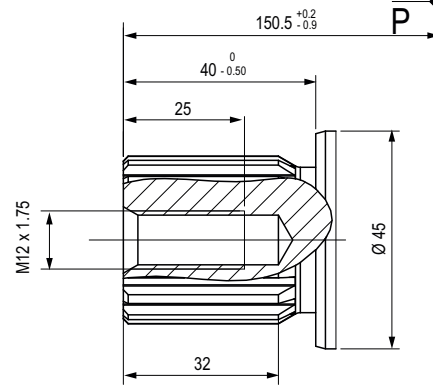

R45 SAE flange ports, bottom 40 degree A and B SAE 1" 6000 psi

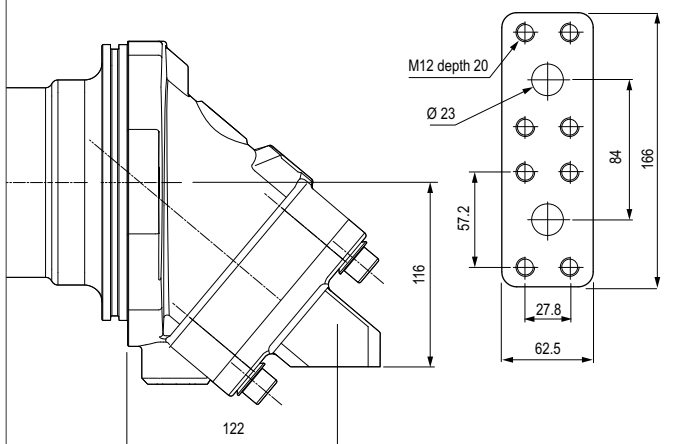

A2FE - 125 cc (Fixed Plugin) - 2 Bolt

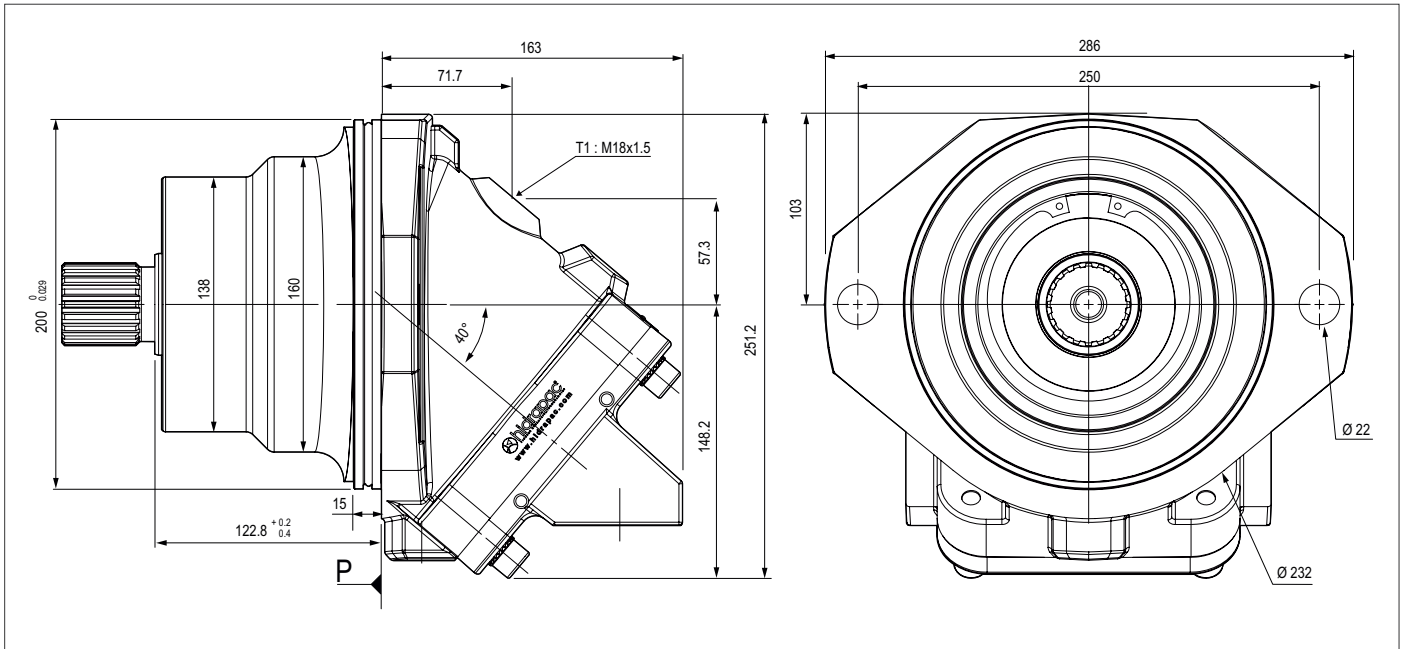

S21 Splined shaft DIN 5480 W 45 x 2 x 30 x 21 x 9 g

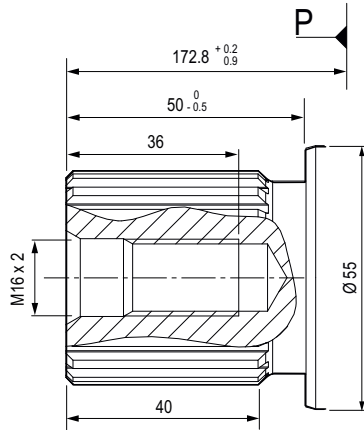

S18 Splined shaft DIN 5480 W 40 x 2 x 30 x 18 x 9 g

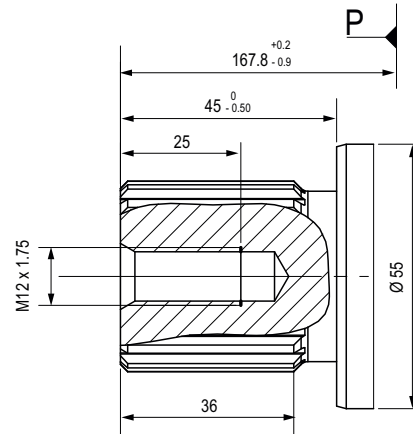

R45 SAE flange ports, bottom 40 degree A and B SAE 1" 1/4 6000 psi

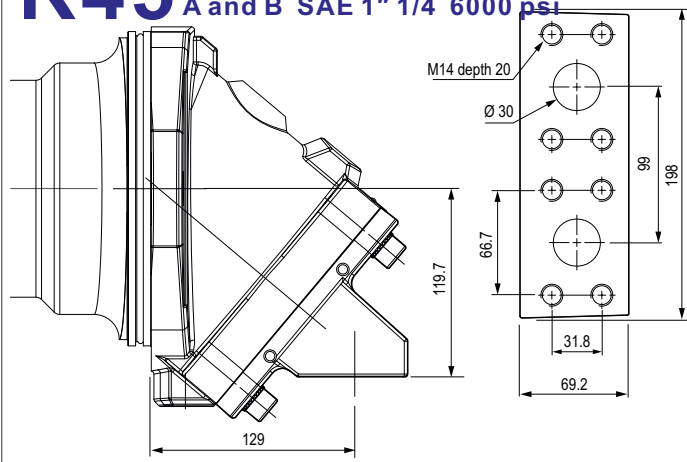

Direction of Rotation; Reversible

The motors rotate clockwise or counter-clockwise depending on the direction of hydraulic flow entering the motor.

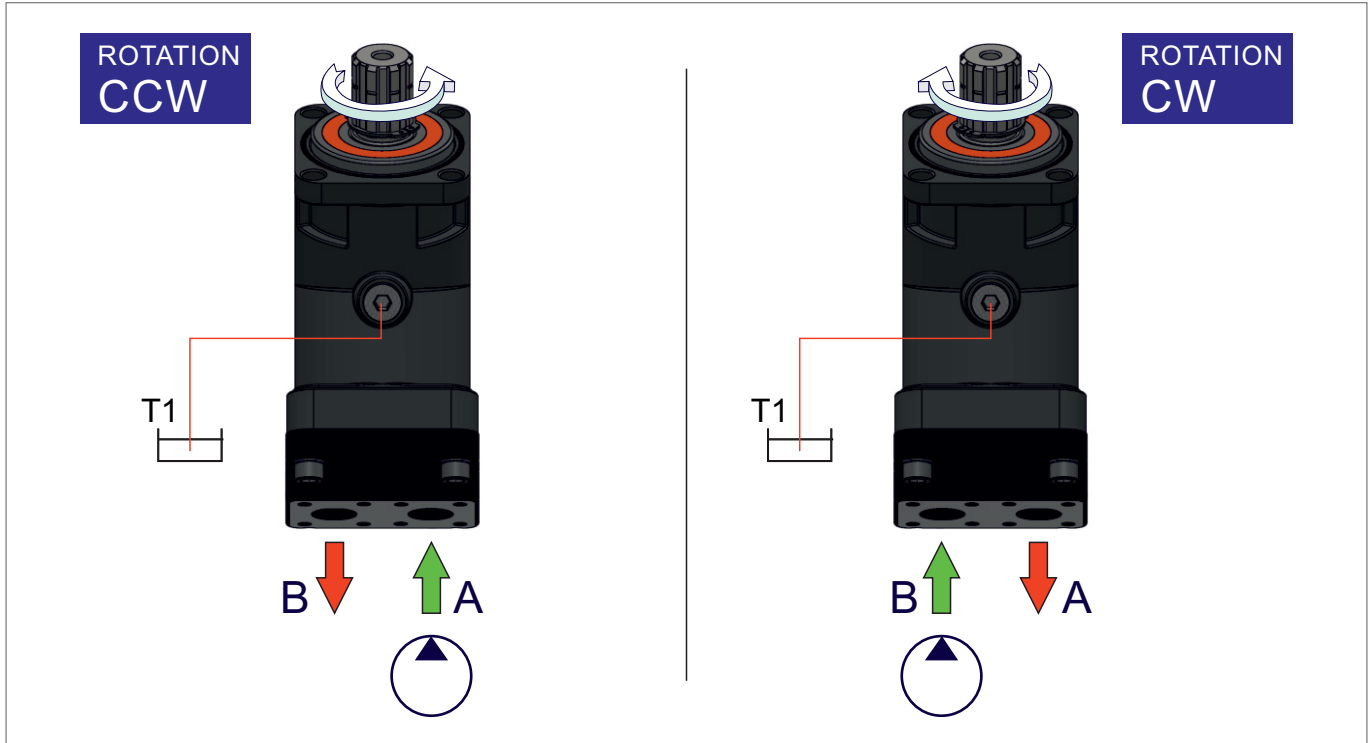

Formulas			
Pump Output Flow	GPM	$GPM = (\text{Speed (rpm)} \times \text{disp. (cu. in.)}) / 231$	$GPM = (n \times d) / 231$
Pump Input Horsepower	HP	$HP = GPM \times \text{Pressure (psi)} / 1714 \times \text{Efficiency}$	$HP = (Q \times P) / 1714 \times E$
Pump Efficiency	E	Overall Efficiency = Output HP / Input HP	$E_{\text{Overall}} = \text{HPOut} / \text{HPIn} \times 100$
		Overall Efficiency = Volumetric Eff. \times Mechanical Eff.	$E_{\text{Overall}} = \text{EffVol.} \times \text{EffMech.}$
Pump Volumetric Efficiency	E	Volumetric Efficiency = Actual Flow Rate Output (GPM) / Theoretical Flow Rate Output (GPM) \times 100	$\text{EffVol.} = \text{QAct.} / \text{QTheo.} \times 100$
Pump Mechanical Efficiency	E	Mechanical Efficiency = Theoretical Torque to Drive / Actual Torque to Drive \times 100	$\text{EffMech} = \text{TTheo.} / \text{TAct.} \times 100$
Pump Displacement	CIPR	$\text{Displcmnt (In.}^3 \text{ / rev.)} = \text{Flow Rate (GPM)} \times 231 / \text{Pump RPM}$	$\text{CIPR} = \text{GPM} \times 231 / \text{RPM}$
Pump Torque	T	Torque = Horsepower \times 63025 / RPM	$T = 63025 \times \text{HP} / \text{RPM}$
		Torque = Pressure (PSIG) \times Pump Displacement (CIPR) / 2π	$T = P \times \text{CIPR} / 6.28$

- Horsepower for driving a pump** : For every 1 hp of drive, the equivalent of 1 gpm @ 1500 psi can be produced.
- Horsepower for idling a pump** : To idle a pump when it is unloaded will require about 5% of it's full rated power
- Wattage for heating hydraulic oil** : Each watt will raise the temperature of 1 gallon of oil by 1° F. per hour.
- Flow velocity in hydraulic lines** : Pump suction lines 2 to 4 feet per second, pressure lines up to 500 psi - 10 to 15 ft./sec., pressure lines 500 to 3000 psi - 15 / 20 ft./sec.; all oil lines in air-over-oil systems; 4 ft./sec.

Installation & Assemble Informations for Bent Axis Motors

POSITION

Fixed Flange Bent Axis Motors can be operate any position.

DIRECTION OF ROTATION

Fixed Flange Bent Axis Motors can be operate in both directions of rotation.

Before of Installation operation, the motor must be filled with hydraulic fluid and air bled.

INSTALLATION POSITION

See following examples.

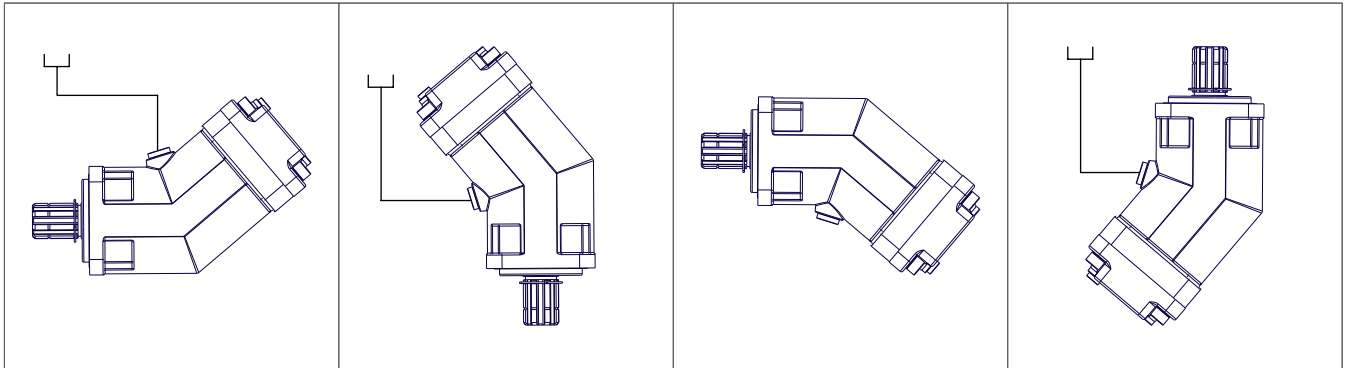

HYDRAULIC FLUID

Recommended ;

Generally : between 15 and 200 cSt.

Maximum : between 5 and 1600 cSt.

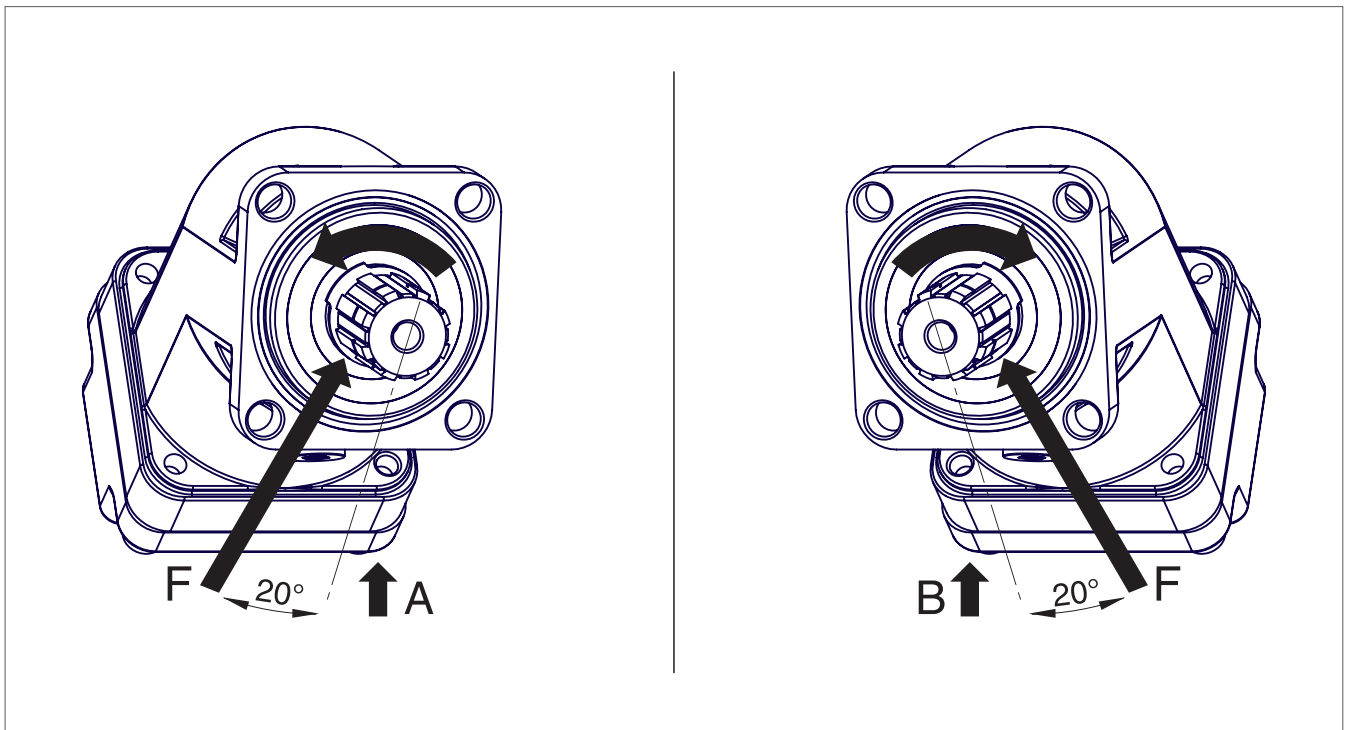

FOR USE;

Available via e-mail on request or each motor is supplied via Starting datasheet.

Formulas, Calculations, Installation Guide

Quick Calculation

Flow rate

$$Q = \frac{V_S \cdot n}{1000 \eta_v} \text{ (lpm)}$$

Torque

$$M = \frac{V_S \cdot \Delta p \cdot \eta_{mh}}{63} \text{ (Nm)}$$

Power

$$P = \frac{2\pi \cdot M \cdot n}{60000} = \frac{M \cdot n}{9549} = \frac{Q \cdot \Delta p \cdot \eta_t}{600} \text{ (kw)}$$

Speed

$$n = \frac{1000 \cdot Q \cdot \eta_v}{V_S} \text{ (lpm)}$$

- V_S = Displacement (ccm/rev.)
- Δp = Diff. pressure (bar)
- n = Speed (rpm)
- Q = Flow (lpm)
- η_v = Volumetric efficiency
- η_{mh} = Mechanical-hydraulic efficiency
- η_t = Total efficiency ($\eta_t = \eta_v \times \eta_{mh}$)

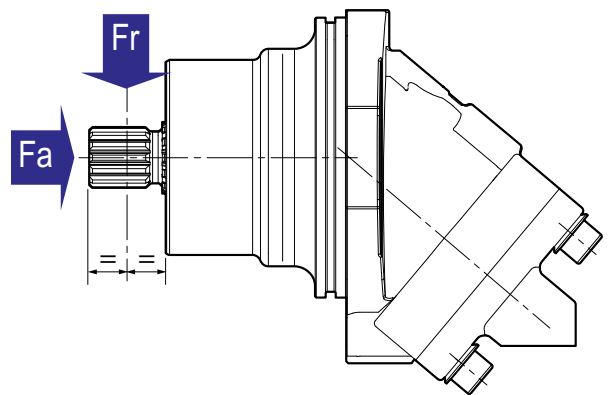

Motor model	28 cc	32 cc	41.45	50 cc	56, 63cc	80,90,108	125 cc
Fr (lbf)	1350	1462.5	1462.5	1686	2023	2812	3262
Fr (N/bar)	6000	6500	6500	7500	9000	12500	14500
Fa (lbf)	0.42	0.46	0.62	0.62	0.77	1.24	1.33
Fa (N/bar)	(27)	(30)	(40)	(40)	(50)	(80)	(86)

Other Advantages of Flange Bent Axis Motors

- Interchangeable and Compatible with other Bent Axis Motors,
- Special Designed Pistons,
- One-Piece Piston with Piston Rings,
- For use in stationary and mobile applications,
- Compact motor design and extra durable parts,
- High Operational Reliability and High Starting Torque
- Extra Warranty with Wide Service

Complete Product Range

Bent Axis Piston Motors

K2FM (DIN) Bent Axis Motor
K3FH (HYBRID) Bent Axis Motor
A2MS (SAE) Bent Axis Motor
A3MS (SAE2) Bent Axis Motor
A2FM (ISO) Bent Axis Motor
A2FE (Fixed Plugin) Bent Axis Motor
A2FE (Two Speed) Bent Axis Motor
A2FT 45 (Inline) Bent Axis Motor

Bent Axis Piston Pumps

K2FA (DIN) Bent Axis Pump
K2FH (HYBRID) Bent Axis Pump
K2FL (Aluminum) Bent Axis Pump
A2FS (SAE) Bent Axis Pump
A3FS (SAE2) Bent Axis Pump
A2FO (ISO) Bent Axis Pump
A3FO (ISO2) Bent Axis Pump
A2FP (Fixed Plugin) Bent Axis Pump

Variable Displacement Motors

AXMV Variable Piston Motor
AXMA Variable Piston Motor
AXMI Variable Piston Motor

Variable Displacement Pumps

AXVP Variable Piston Motor
AXVA Variable Piston Motor
AXVI Variable Piston Motor

Dual Flow Piston Pumps

A2FD (DIN) Dual Flow Pumps
A2FD (SAE) Dual Flow Pumps
A2PD Axial Dual Output Pumps

Axial Piston & Gear Pumps

A3PP Axial Piston Pumps
A3PH High Pressure Pumps
A2GP Gear Pumps
A2GPT Tandem Gear Pumps
A2GM Gear Motors
A2GMT Tandem Gear Motors

Valve (ByPass) (Flushing) (Cavitation)

Circulation Valve
ByPass Valve
Anti-Cavitation Valve
Flushing Valve
LS Valve
AntiShock Valve
Speed Sensor

Hydraulic Spare Parts

Suction Fittings
Couplars
Adapters
Flanges
Power Take Off
Monoblock Valve
Section Valve

Hydraulic Pumps, Motors

Bent Axis Hydraulic Piston Motors, Bent Axis Hydraulic Piston Pumps, Bent Axis Motors, Variable Displacement Piston Pumps, Variable Displacement Piston Motors, Axial Piston Pumps, High Pressure Piston Pumps, Gear Pumps, Gear Motors, Hydraulic Valve.

www.HIDRAPAC.com

Address;

HIDRAPAC HİDROLİK İÇ VE DIŞ TİC LTD ŞTİ

Address; Fevzicakmak Mah. Sıla Cad. Kobisan 3 San. Sit.
No:73 / C Karatay – Konya, PO Code; 42050, Türkiye

Phone; +90 551 111 77 44

VAT Number; 462 077 9143

www.HIDRAPAC.com

MAIL@HIDRAPAC.com

INFO@HIDRAPAC.com

Hidrapac **Store**

www.HIDRAPAC.com.tr

Hidrapac **Premium**

www.HIDRAPACHYDRAULIC.com